

## 1. CONNECTION AND SETTING UP OF THE INSTRUMENT

### 1.1 The measuring principle of flowmeter FLOWMEX® classic

According to the Faraday law of electromagnetic induction voltage is induced in conductor, which moves in the magnetic field. The running liquid figures as the moving conductor in case of measuring liquid by inductive flow meter. Inductive voltage is directly proportional to the speed of flowing. This voltage is scanned by two electrodes and brought to the measuring part of electronics where it is evaluated. The volume of running medium is automatically counted from the speed of flowing liquid and known diameter of a pipe.

Flow meter **FLOWMEX® classic** is determined for measuring of the amount of flow liquid medium with conduction  $2\mu\text{S}/\text{cm}$  at least. Among most common applications belong usage for measuring of flow in water and sewerage systems, industrial and technological processes, abutments of houses and elsewhere. Extra variants of the meter are **FLOWMEX® food** for food applications and **FLOWMEX® dosing** with an output for control of electromagnetic valves and pumps.

### 1.2 Starting the meter

Terminal board for connection cables is placed inside the box. It is possible to take off the cover after removing two covering ledges on the front board and unscrewing screws. Connection is practised without supply voltage in this order.

- ✓ Into the clamps 4,5,14,15 and 16 connect cable of inductive flow sensor according to the table (see p. 2)
- ✓ If you want to use the function of meter for conversion of the volume of water to the mass connect the connecting cable of resistive temperature sensor to clamps 10, 11.
- ✓ In case of using circuits of meter for communication put corresponding outlet of connecting cable into the clamps 3a, 3b, 6,7,8 and 9.
- ✓ Bring supply voltage 230V/50Hz by individual cable without a switch with its own protection into the clamps 1 and 2 according to the table. We advise to use cable CYKY 2x1,5.
- ✓ Check the connection, screw the bottom and upper board down and switch in the supply voltage.
- ✓ After checking the working of the meter, put on the covering ledges and seal the meter.

### 1.3 Setting up the meter and the outputs 2 and 3

Setting-up a meter and configuration of outputs are practised by insertion of jumper J1 inside the box (see pic.). Cursor appears on the display. It will move from left to right in period of 2 sec. The data, under which the cursor is, is set up by clinch the button (increase the number value switch among possibilities).

The instrument is delivered pre-set by the producer in configuration according the demands of customer, which he gives in his order. In spite of this fact the user can set up some data or change the configuration of outputs 2 (clamp 6,7) or 3 (clamps 3a, 3b) by himself.

The method and survey of adjustable parameter and configuration of outputs are given in the manual *Configuration of the outputs CALMETEX/FLOWMEX*.

### 1.4 Components of meter

- ✓ **flow sensor** of required type, separated version with 4 m cable (10m on request)
- ✓ **bolts** a part of delivery only with ceramic and flange version
- ✓ **converter** of the meter
- ✓ user's manual, certification of guarantee, documentation, copy of approval TCM 311-3098 by CMI
- ✓ certificate of verification of meter on reques

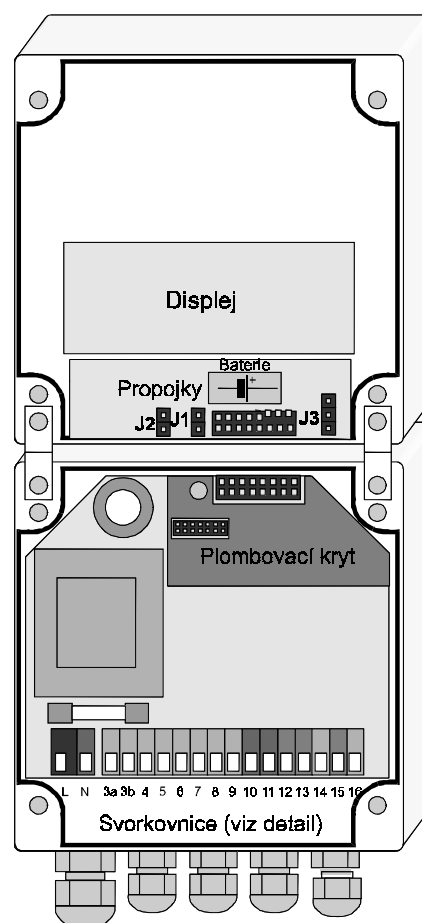

### 1.5 Connection of terminal board

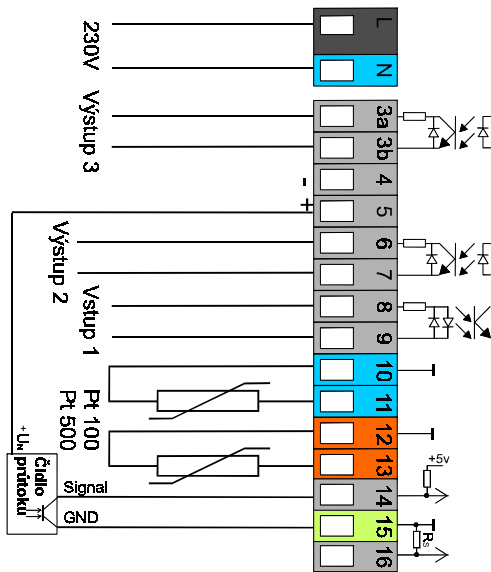

č.	clamp	cabel	description
1	dark grey	L - phase	Power supply 230V~ 50 Hz
2	blue	N – nulový vodič	
3a	grey	+ Colector	Output signal 3 max. 30V/15 mA
3b	grey	- Emitter	
4	grey	black	Flow sensor-excitation
5	grey	brown	
6	grey	+ Colector	Output signal2 max. 30V/15 mA
7	grey	- Emitter	
8	grey	+ Anode	Input signal 1 min. proud 3 mA
9	grey	- Cathode	
10	blue	Temperature sensor (not necessary)	Only when utilize VARIANT 10
11	blue		
12	orange		
13	orange		
14	grey	green	Flow sensor - signal
15	green	shadowed	
16	grey	white	

## 2. CONTROL OF THE INSTRUMENT

### 2.1 Diagram of displayed information

#### Legend

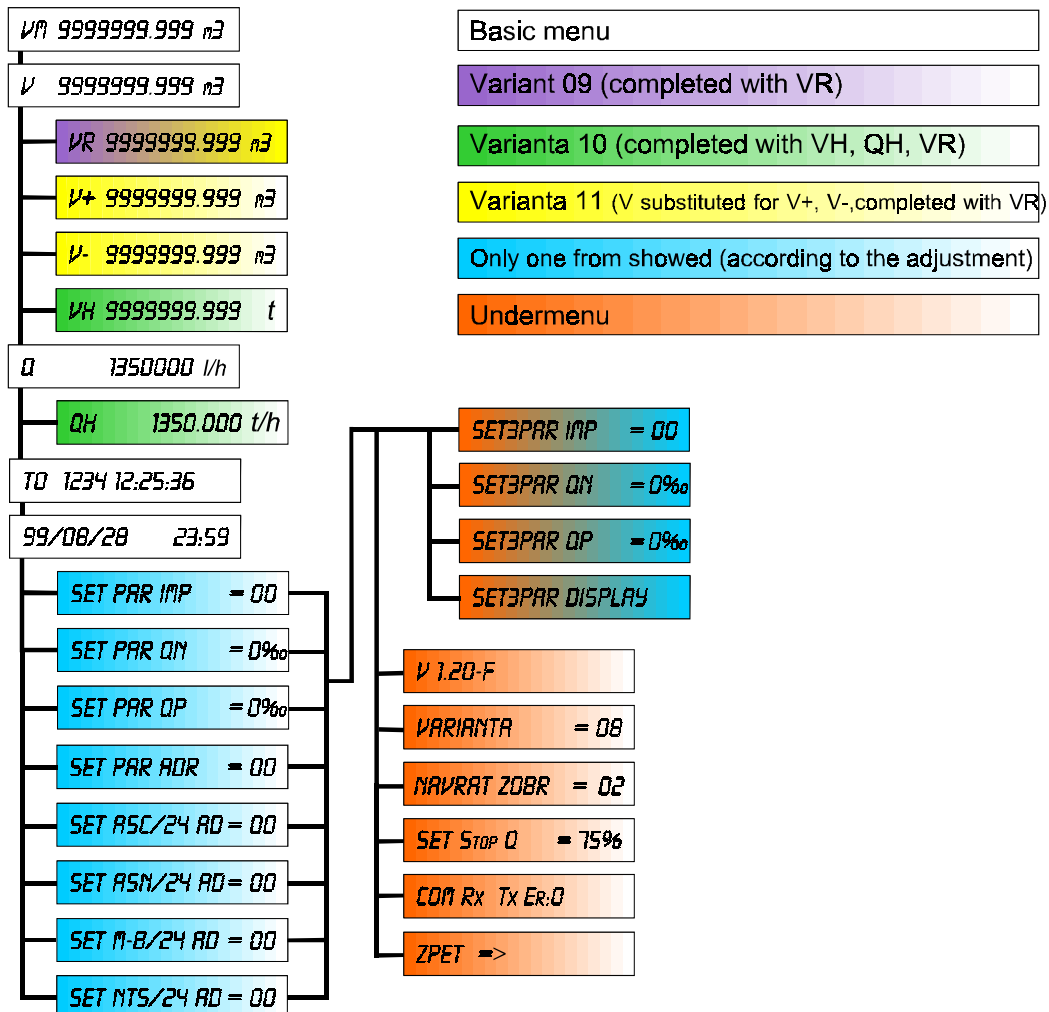

## 2.2 Move among displayed data

The converter is equipped with a button. It is possible to display required values by successive pressing. Next data is displayed by short press (<3 sec.), in case of long press (>3 sec.) you can pass over to the other level of displayed data / only on some data (see Diagram of displayed data). It is possible to return to the main menu in the same way. Where it is not possible to pass over to another level and back you activate an auto-repeat of the button by long press - automatic re-pressing with fluent shortening of interval from 1,7 to 0,35 sec. Where to pass-over is possible the button reacts to the short pressing as late as releasing the button. In case of long press it passes-over to the submenu after 3 sec.

## 2.3 Data displayed in the basic menu

Data	Meaning	Unit	Size of displaying
VM	Suma of flow volume of the last month	m <sup>3</sup>	V <sup>M</sup> 9999999.999 m <sup>3</sup>
V	Continual counter of total volume	m <sup>3</sup>	V 9999999.999 m <sup>3</sup>
Q	Actual flow of medium	l/h	Q 1380000 l/h
TO	Total length of voltage failure	dny h:m:s	0037 12:13:14
Datum a čas	Date and time	r/m/d h:m	00/09/20 10:00
<b>Configuration of output 2:</b> (one of following adjustable data is displayed according to the configuration)			
SET PAR IMP	Adjustment of pulse constant for flow pulses		SET PAR IMP = 01
SET PAR QN	Adjustment of threshold output for flow		SET PAR QN = 0 % <sub>00</sub>
SET PAR QP	Adjustment of threshold output for flow		SET PAR QP = 0 % <sub>00</sub>
SET PAR ADR	Adjustment of series communication, protocol CAL-P		SET PAR ADR = 01
SET ASC/24 AD	Series comm. with protoc. CAL-P with adjustable speed		SET PAR ASC/24 AD = 01
SET ASN/24 AD	Adjustment of series communication, protocol CAL-N		SET PAR ASN/24 AD = 01
SET M-B/24 AD	Adjustment of series communication, protocol M-BUS		SETPAR M-B/24 AD=01
SET NT5/24 AD	Adjustment of series comm., protocol NET5.1-V2.1		SETPAR NT5/24 AD=01
<b>Variant 09:</b> (resetable relative counter VR is displayed when you adjust variant 09 (besides those above))			
VR	Volume counter, reset is done by long press	m <sup>3</sup>	VR 9999999.999 m <sup>3</sup>
<b>Variant 10:</b> (Following data is displayed when you adjust variant 10 (besides those above))			
VH	Mass counter of flow water	t	VH 9999999.999 t
QH	Actual mass flow of medium	t/h	QH 9999999.999 t/h
<b>Variant 11:</b> (following data for two-way measurements displayed, as well as resetable relative counter, see variant 09 )			
V +	Volume flow. through the positive direct of flow sensor	m <sup>3</sup>	V+ 9999999.999 m <sup>3</sup>
V -	Volume flow. through the negative direct of flow sensor	m <sup>3</sup>	V- 9999999.999 m <sup>3</sup>

## 2.4 Data displayed in submenu of the meter

Data	Meaning	Size of displaying
Version	Software version	V 1.20-F
Variant	Variant of displaying of the meter (see the table before)	VARIANTA = 08
Návrat zobr.	Number of display on which it returns after passing a time without press the button	NAVRAT ZOBRA = 02
SET STOP Q	Adjustment of threshold for measuring the flow in % from Q <sub>min</sub> , on which meter shows a zero flow. Adjustable range is 10-90%.	SET STOP Q = 75 %
COM Rx Tx Er:0	Data of series communication (only for service proposes)	COM Rx Tx Er:0
ZPET =>	Data for pass-over back to the main menu (long press)	ZPET =>
<b>Adjustment of communication output 3:</b> (one of following adjustable data is displayed according to the configuration of meter)		
SET3PAR IMP	Adjustment of pulse constant for flow pulses	SET3PAR IMP = 00
SET3PAR QN	Adjustment of threshold output for flow	SET3PAR QN = 0 % <sub>00</sub>
SET3PAR QP	Adjustment of threshold output for flow	SET3PAR QP = 0 % <sub>00</sub>
SET3PAR DISPLAY	Adjustment of output for distant display	SET3PAR DISPLAY

The way of configuration, possibilities and meaning of adjustment of single communication outputs as well as the tables of pulse constants are given in manual *Configuration of outputs of the meter CALMETEX/FLOWMEX*.

## 2.5 Pass-over to the submenu and back

Pass-over to the submenu by long press the button on the data SET PAR IMP (or SET PAR IMPE, SET PAR QN, SET PAR QP, SET PAR ADR, SET ASC/24 AD, SET ASN/24 AD, SET M-B/24 AD or SET NT5/24 AD according to the chosen configuration of the meter). Return – long press on any data of submenu

## 3. BASIC TECHNICAL INFORMATION OF METER FLOWMEX

### 3.1 Certificated range of flow

DN	mm	8	10	15	20	25	32	40	50	65	80	100	150	200
Q <sub>min</sub>	m <sup>3</sup> /h	0,03	0,042	0,098	0,18	0,27	0,45	0,68	1,08	1,80	2,70	4,20	9,75	17,25
Q <sub>nom</sub>	m <sup>3</sup> /h	1,00	1,40	3,25	6,00	9,00	15,0	22,5	36,0	60,0	90,0	140,0	325,0	575,0
Q <sub>max</sub>	m <sup>3</sup> /h	2,40	3,36	7,80	14,4	21,6	36,0	54,0	86,4	144,0	216,0	336,0	780,0	1380

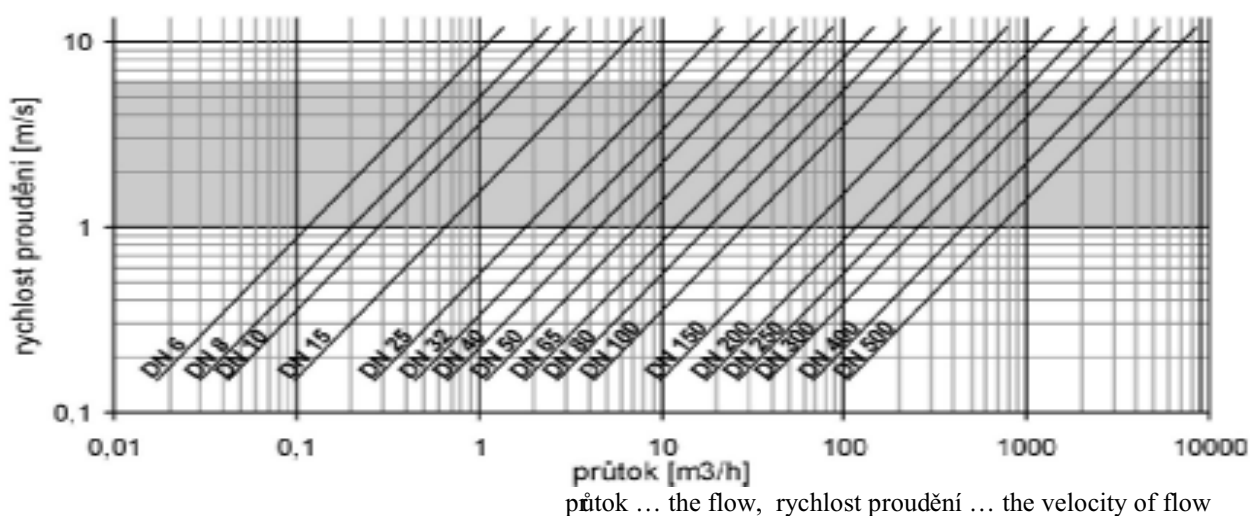

### 3.2 Converter - technical information

Power supply.....	230V ± 10%, 50Hz
Consumption.....	cca 9 VA
Level of protection.....	IP 65
Dimensions.....	120 x 120 x 60 mm
Temperature range of measurement.....	4 to 170 °C
Temperature difference.....	3 to 166 °C
Backup of data.....	min. 30 years v EEPROM
Bushings.....	4 x PG 7, 1x PG 9
Display.....	LCD 16 symbols
Max. of oppressing of outputs.....	30V/15mA
Min. current of input.....	I > 3mA

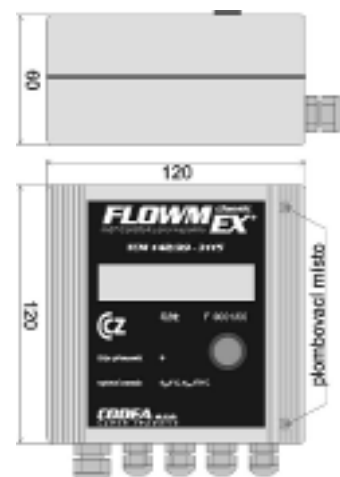

### 3.3 Material of flow sensor with ceramic cell

Lining.....	highly resistant ceramic tube with 99,7% content of corundum Al <sub>2</sub> O <sub>3</sub> .
Max. temp. of medium..	160 °C
Front surfaces.....	standard galvanized steel 11.373, or stainless steel 17.348, others on request.
Flanges.....	PN 40 (DN 8 - 80) / PN 25 (DN 100 - 200) – according to ČSN, DIN on request.
Level of protection.....	IP 67
Electrodes.....	standard stainless steel 17.348. Titanium, Hastelloy or other materials on request
Packing.....	silicone
Outside cover.....	cast iron protected with comaxit colour.

### 3.4 Dimensions a shape of the sensor with ceramic lining

DN	Dimension of flow sensors with ceramic lining										Bolts (sandwich)		
	D1	D2	D3	D4	D5	L1	L2	L3	L4	d	Ø	length	number
8	51	65	–	–	–	91	100	–	–	–	M12	180	4
10	51	65	–	28×1/8“	–	91	100	–	138	–	M12	180	4
15	51	65	95	34×1/8“	–	91	100	224	138	14	M12	180	4
25	71	85	115	52×1/6“	–	93	102	228	156	14	M12	180	4
32	82	100	140	58×1/6“	–	113	122	256	182	18	M16	210	4
40	92	110	150	65×1/6“	–	113	122	268	184	18	M16	210	4
50	107	125	165	78×1/6“	142	119	128	280	194	18	M16	225	4
65	127	145	185	95×1/6“	162	119	128	296	204	18	M16	225	8
80	142	160	200	110×1/4“	–	137	144	336	230	18	M16	250	8
100	168	190	235	130×1/4“	–	141	148	364	252	22	M20	250	8
150	224	250	300	190×1/4“	–	177	184	434	280	26	M24	310	8
200	290	310	360	–	–	237	244	536	–	26	M24	390	12

Sensor with ceramic lining - sandwich

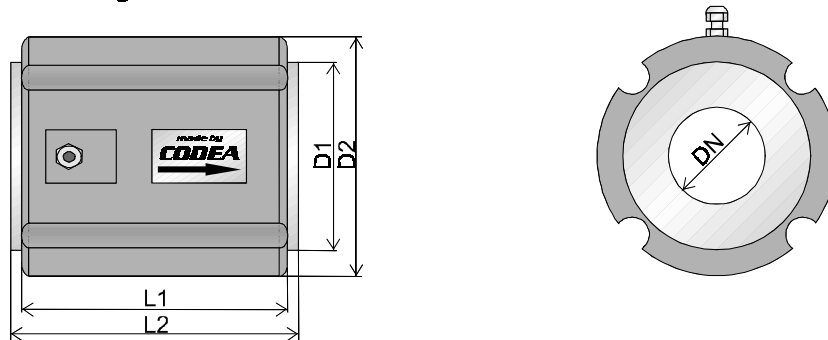

Sensor with ceramic lining - flange

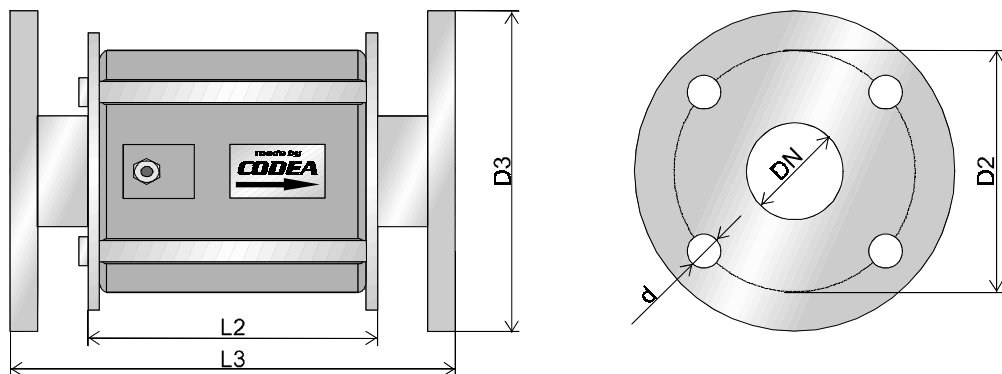

Sensor with ceramic lining - food screw joint

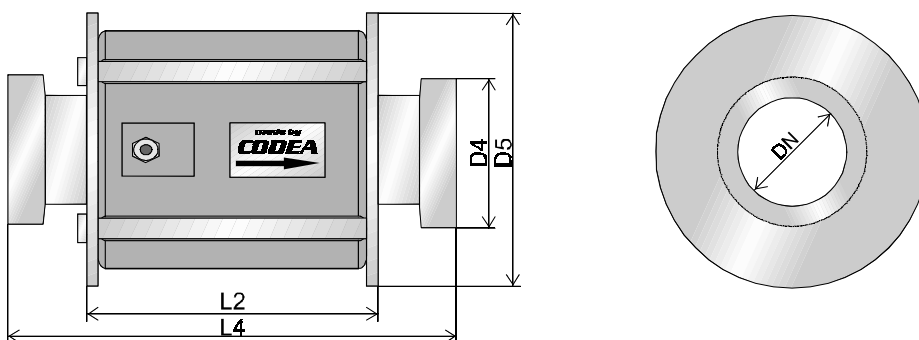



## 4. INSTALLATION OF SENSOR INTO THE PIPE

### 4.1 General principles of installation

If the meter is used for invoicing measuring and not only as operational meter it may be installed only by organization which was trained to this purpose. Company CODEA Ltd. gives written Certificate of qualification based on training.

- ✓ The cable bushing of sensor directs up at horizontal installation
- ✓ It is necessary to be careful of heavy strokes and shocks on sensor.
- ✓ The sensor electrodes mustn't be greased up or insulated. If those happened the electrodes must be cleaned before installation.
- ✓ Pararellism of packing parts must be as requested CSN 131005 or equivalent ISO norm and the tolerance of pararellism of packing parts mustn't over-reach 2 % of the diameter of packing part.
- ✓ Sensors in sandwich are installed between flanges by bolts, which are parts of delivery.

### 4.2 Location and position

Position of sensor is indifferent. The meter is possible to build into as rising so horizontal pipe (sse A): Suitable position is when firm particles do not settle at the bottom or electrodes of sensor, air pockets and bubbles which stretch the measuring are not created and electrodes are not uncovered – they must be dipped all time. That is why we recommend:

- ✓ Electrode axis is to be horizontal in horizontal position of sensor (the bushing directs up) or max. 45° from horizontal position so as to prevent from short-time insulation of electrodes by bubbles.
- ✓ Ascending or vertical position is optimal for liquid that contains firm particles by reason of prevention from settling particles in its discharge profile and on electrodes.
- ✓ Install the sensor to the ascendant trap when the pipe is partly depleted or not full. It is not advisable to install the sensor at the bottom of a trap because of silting profile by deposits (see B)
- ✓ In case of decreasing pipe by more than 5m install the sensor before air escape valve to the trap (see D).
- ✓ Do not install the sensor on the suction side of a pump by reason of creation of underpressure (see E).
- ✓ Do not install the sensor in the highest point of a pipe by reason of creation of bubbles and air locks (F).
- ✓ do not install the sensor before outlet for the same reason. (see G).
- ✓ Optimal position is a place of stable flow in speed more than 1m/s.

It is advisable to install a soothing pipe in length of 5 DN at least before the sensor and 3 DN behind it so as the lamination of flow is ensured (see C).

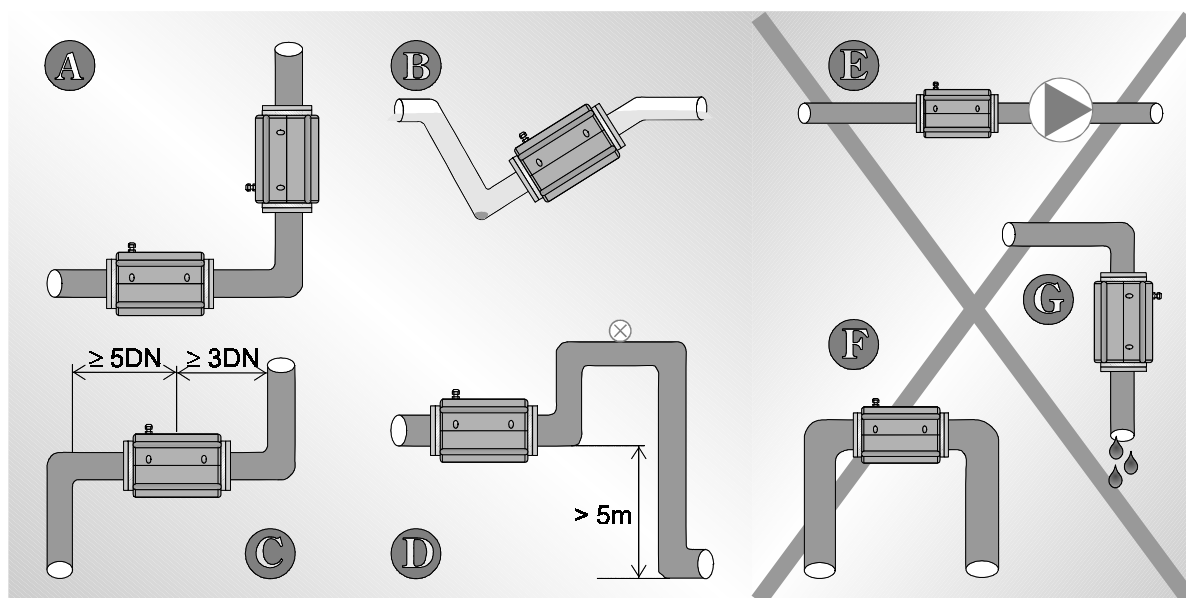

### 4.3 Reduction and pressure lost

In case of low speed of liquid flow it can be advisable to reduce the pipe so as the speed rises and hereat the pressure loss was not too high. We recommend using confusors and difusors with the side angle  $\alpha \leq 8^\circ$ . It is possible to count in such reduction into the soothing lengths (see chapter 4.2.). In case of using reduction with greater rising it is necessary to insert soothing pipe of appropriate length between the sensor and the reduction. The graphs of pressure losses for various diameters of reduction  $d1/d2$  with side angle  $\alpha = 8^\circ$  (top angle  $2\alpha = 16^\circ$ ) are given below. The left graph shows pressure losses of various  $v_2$  (speed of flow in the reduced part of a pipe and a sensor), the right one shows pressure losses for various  $v_1$  (speed of flow in an unreduced pipe).

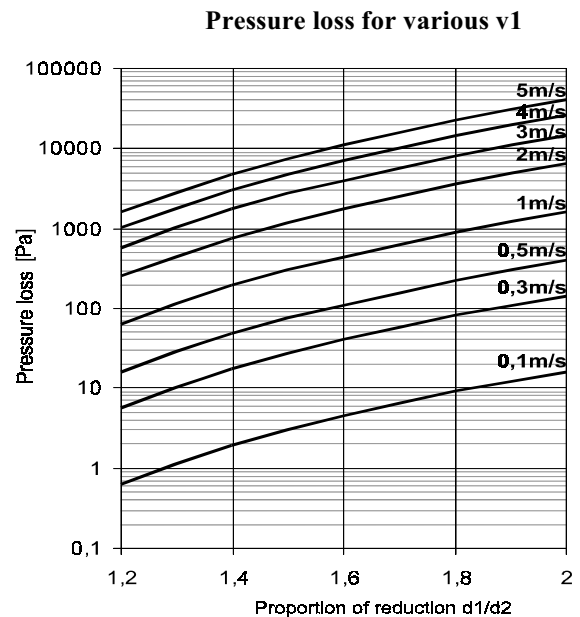
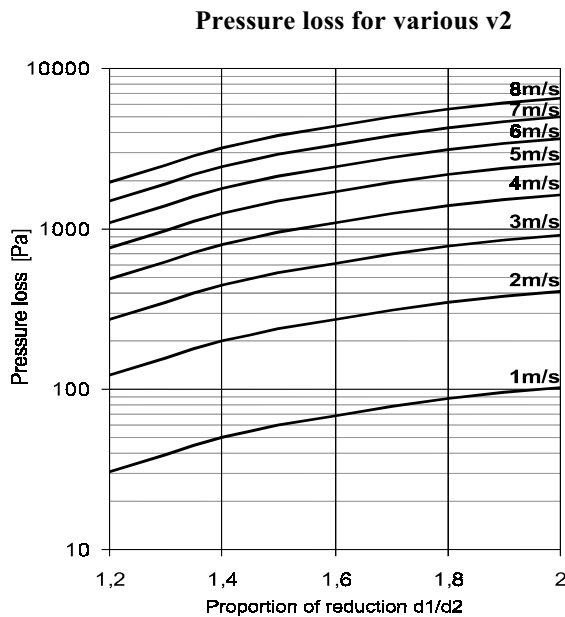
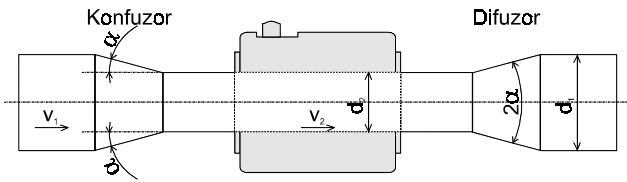

### 4.4 Demands for measured medium

Measured medium must be an electric conducting liquid without adhesive elements that would insulate the electrodes of meter (fat, adhesive resin). The meter measures already from lower conductivity ( $2.5 \mu S/cm$ ) but conductivity of medium  $20 \mu S/cm$  at least is suitable for reaching greater accuracy. Inside pipe cannot be steam and great changing of temperature.

## 5. CLOSING INFORMATION

### 5.1 Possibilities of communication

The instrument has 2 communication outputs configurable according to the wishes of a customer. The table below shows possible combinations for single outputs. For more details see the manual *Configuration of outputs of meter CALMETEX/FLOWMEX*, *Communication interface of meter CALMETEX/FLOWMEX* and *Communication protocols of meter CALMETEX/FLOWMEX*.

Output		Type of communication	Standard	On request
2	3			
		Pulses of flow (adjustable number pulse/l)		
		Pulses of energy (adjustable number pulse/l)		
		Threshold output for flow it clips at exceeding value up		
		Threshold output for flow it clips at exceeding value down		
		Current output 4-20 mA (flow)		
		Output for series communication (ASCII protocol, interface with optoterm)		
		Module of interface RS 232 (external-connecting more meters on one interface)		
		Module of interface RS 422		
		Module of interface RS 485		
		M – BUS		

## 5.2 Saving the data

The data is saved even in case of supply voltage failure in memory EEPROM for time of 30 years. The data *Length of power supply failure* is showed on a display after recovery of power supply.

## 5.3 Defects and their elimination

- ✓ Display does not shine – power supply failure of a meter. Recover the power supply.
- ✓ The data *Temperature difference* shows value  $dT\ 599^{\circ}\text{C}$  – disconnection or damage of some resistive heat sensors. Examine their connection.
- ✓ In case of other damages or atypical features contact the service of producer. Do not tamper with the instrument by yourself.

## 5.4 Maintenance

The instrument does not need any maintenance when installed correctly. In case of specific applications we recommend the servicing by the producer according to the conditions of application.

The validity time of verification of meter FLOWMEX<sup>®</sup> is assessed by the announcement of MPO ČR. This is not compulsory if the meter is not used as an invoicing meter.

## 5.5 Safety regulations

Attendants are entitled to manipulate with the meter within previous regulations. Non-allowed manipulation can lead to an accident. The meter is under permanent voltage 230V and the flow sensor can be exposed to high pressure and temperature running medium. In case of unskilled manipulation or attempt at demounting it can come to an accident by the current or to a scalding.

## 5.6 Encroachment upon the meter and service

The parameters of the meter are adjustable by the producer before dispatch according to the demands of user. After official verification the meter is sealed with mechanic seal on the flow sensor, inside the evaluation unit and on the outside cover of evaluation unit.

**It is not allowed to change the configuration of a meter, pull down or damage the seals in other way, take the meter to pieces or otherwise impair it in any way. It is not allowed either to change, abbreviate or extend the cable between the flow sensor and evaluation unit or the cable of resistive temperature sensors and interrupt the voltage of a meter purposely. Such activity results immediate ending of guarantees and metrology verifications of the meter.**

The producer or accredited agents make all repairs and service. The address of the producer:

---

**CODEA spol. s r.o.**

Korunní 6 (registered office), Přemyslovců 30 (administration)

709 00 Ostrava, Czech republik

tel., fax: +042/596 621 395, 97, e-mail: [codea@codea.cz](mailto:codea@codea.cz)

---

**Contact people:** Ing. Zdeněk Masný CSc. – consultation of technical solutions  
 Ing. Iva Fajkisová – orders, basic business information  
 Ing. Martin Pobořil – metrology, technical information  
 Mr. Karel Pomajbík – service

---

*měřit lze ledacos ...*

*... my měříme pokrok*

